

Design: Hollow piston cylinder, double-acting

Example of ordering: **8.2291.1 110**

Rapid clamping system with **hollow piston cylinder** as clamping element
T-slot: 28 mm
Travelling path: 19.6 in

Functional dimension 'f' (in mm) to be quoted in the order

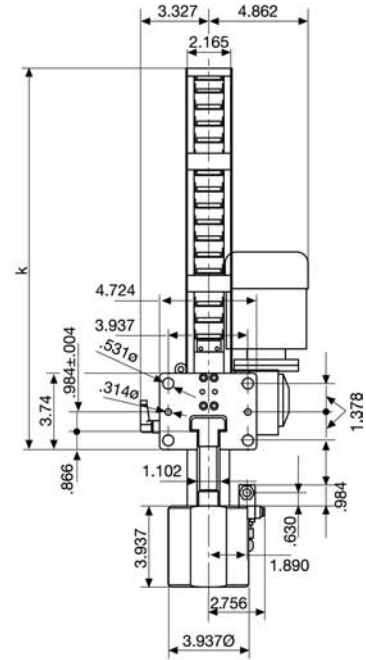
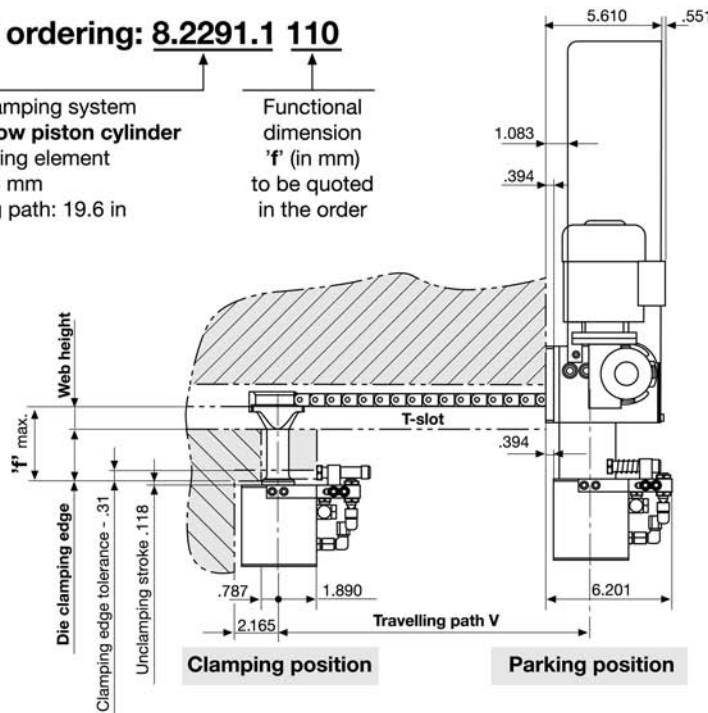

Part no.	T-slot to DIN 650 (mm)	Clamping force at 5,800 psi (lbs)	Operating pressure (psi)	Oil consumption/clamping/unclamping (in ³)	Travelling path V (in)	Dimension k (in)	Clamping dimension 'f' tolerance (in)
HCR-8.2291.1xxx	28	28,875	5,800	.18 / .24	19.6	18.5	+0.0/- .31
HCR-8.2291.2xxx	28	28,875	5,800	.18 / .24	39.4	28.0	+0.0/- .31

Technical data:

Travelling path V	see table *)
Travelling speed	5.6 in/s
Width of T-slot	see table DIN 650 *)
Motor voltage	24 VDC
Rated motor current	3.3 A
Motor output	80 W
Two proximity switches	24 (10-30) V DC *)
Parking position	
Die position	
A further proximity switch for "End of chain" is available on request	
Motor connection	Harting HAN3HVE *) (plug with 19.6 in. cable length)
Connections for proximity switches	Harting HAN10E *) (plug with 19.6 in. cable length)
Hydraulic connection	Union nut M 14 x 1,5 *) (free hose length 19.6 in.)

*) other versions as well as a spindle drive are available on request.

