

Carrying Consoles

for easy and efficient die change on the press bed

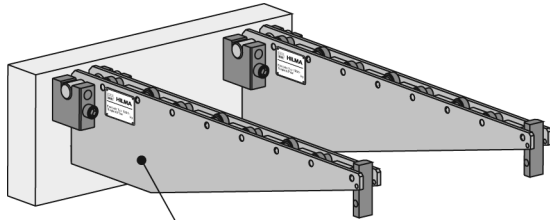

Color: RAL 1004, golden yellow

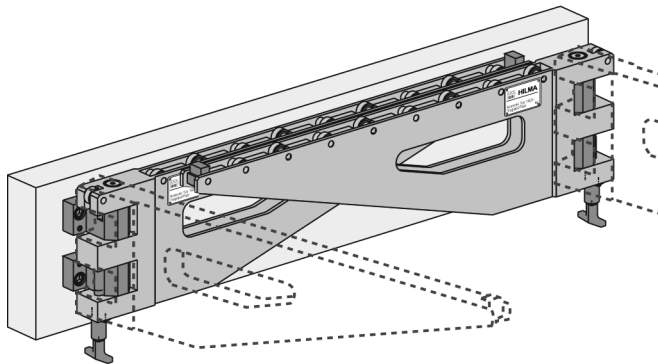
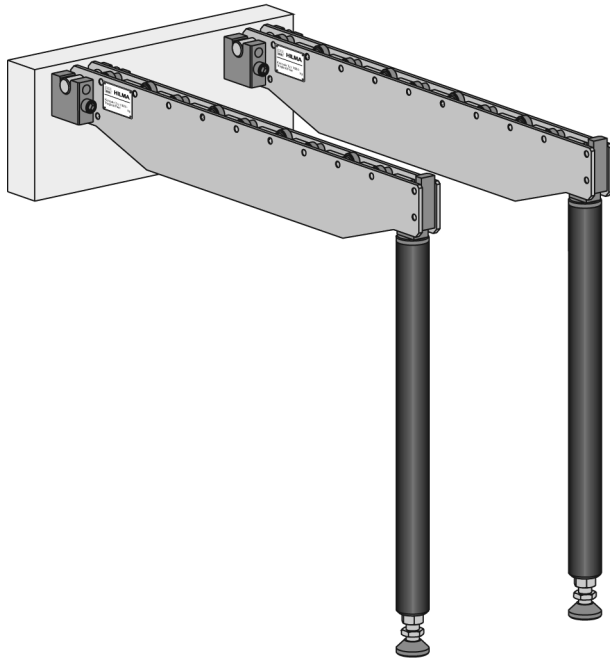

Carrying console, hanging

The carrying consoles are hung in the hooks on the die changing side of the press. The hooks are supplied with the consoles. The consoles are used as a pair only. Their size must be selected to suit the highest die weight.

The die is loaded onto the consoles using a crane or a forklift truck. The carrying rollers consist of high-strength hardened needle bearings. The end stop can be bypassed in one direction only.

The surface is provided with a shock-resistant coating in RAL 1004, golden yellow.

Hanging consoles may be used for several presses. In this case, an additional set of hooks is required.

Carrying console, supported

In order to cope with heavy and large dies, the hanging console is provided with an additional support.

For compensating for unevenness on the floor, the supports are designed as adjustable supports with a ball-and-socket joint. The height may be changed subsequently by ± 60 mm. The end stop can be bypassed in one direction only.

Carrying console, swivelling

This console is permanently fastened to the press bed and can be pivoted into the die changing position. This type is particularly recommended when the available space in front of the press bed is limited, or if removal and intermediate storage of the console is not possible or required.

For carrying rollers, end stop and surface coating, see above.

Special designs of carrying consoles are available on request.