

BM-Rollblocks – Rectangular Style

for ASA T-slots
mechanical ball type

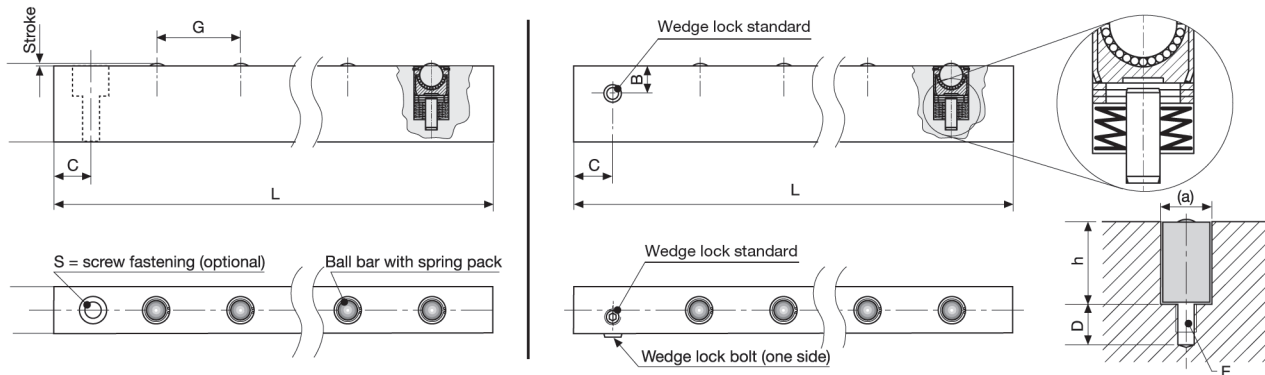

Application

These rollblocks are used in pairs or sets to lift the die and provide a surface of precision balls allowing the die to be easily rolled in and out during the die change process. For use in ASA B5.1-1949 T-slots specification or rectangular slots meeting the dimensional requirements stated. Deeper T-slots can be shimmed to suit. Ball style rollblocks are suited for lighter loads than roller style, and in some cases require hardened wear strips to be installed on the bottom of the die to reduce tracking.

Description

The rollblock consists of a bar that is equipped with spring operated supporting balls for movement both inline and transverse with the bar.

Advantages

- each ball can provide both linear and transverse movement
- rollblock includes wedge lock or optional screw retainers
- each ball is seated in a pre-lubricated nest of ball bearings
- rolling resistance is 2-4% of die weight

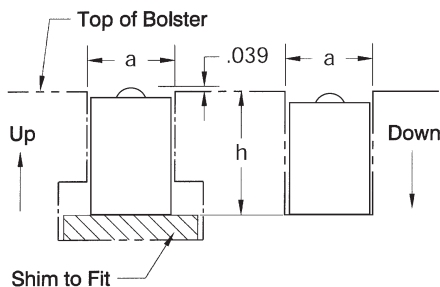

Slot (a) (in)	Slot (h) (in)	Stroke (in)	B (in)	C (in)	D (in)	E (mm)	G (in)
13/16	1.16	0.039	0.47	0.39	0.59	M6	1.18 (30 mm)
1 1/16	1.53	0.039	0.51	0.49	0.79	M8	1.58 (40 mm)

Part No.	L (in)*	Max Load Per Ball (lbs)	Max Lift Capacity (lbs)	# of Balls	T-slot Size
HCR-BM-13-4-G30	5.12	45	180	4	13/16"
HCR-BM-13-6-G30	7.48	45	270	6	13/16"
➔ HCR-BM-13-8-G30	9.84	45	360	8	13/16"
➔ HCR-BM-13-10-G30	12.2	45	450	10	13/16"
➔ HCR-BM-13-12-G30	14.8	45	540	12	13/16"
➔ HCR-BM-13-14-G30	16.93	45	629	14	13/16"
➔ HCR-BM-13-16-G30	19.29	45	719	16	13/16"
➔ HCR-BM-13-18-G30	21.65	45	809	18	13/16"
➔ HCR-BM-13-24-G30	28.74	45	1,079	24	13/16"
➔ HCR-BM-13-30-G30	35.83	45	1,349	30	13/16"
➔ HCR-BM-13-35-G30	41.73	45	1,574	35	13/16"
HCR-BM-17-4-G40	6.89	90	360	4	1 1/16"
HCR-BM-17-6-G40	10.04	90	540	6	1 1/16"
➔ HCR-BM-17-8-G40	13.19	90	719	8	1 1/16"
➔ HCR-BM-17-10-G40	16.34	90	899	10	1 1/16"
➔ HCR-BM-17-12-G40	19.49	90	1,079	12	1 1/16"
➔ HCR-BM-17-14-G40	22.64	90	1,259	14	1 1/16"
➔ HCR-BM-17-16-G40	25.79	90	1,439	16	1 1/16"
➔ HCR-BM-17-18-G40	28.94	90	1,619	18	1 1/16"
➔ HCR-BM-17-24-G40	38.39	90	2,158	24	1 1/16"
➔ HCR-BM-17-30-G40	47.83	90	2,698	30	1 1/16"
➔ HCR-BM-17-36-G40	57.28	90	3,237	36	1 1/16"
➔ HCR-BM-17-42-G40	66.73	90	3,777	42	1 1/16"
➔ HCR-BM-17-48-G40	76.18	90	4,316	48	1 1/16"

➔ Stock parts

Add suffix -s to part number for screw mounting

*Intermediate, Metric and Longer Versions

BM-Ball Mechanical Rollblock

for **METRIC** and ASA specials

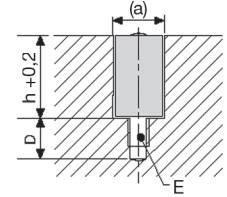
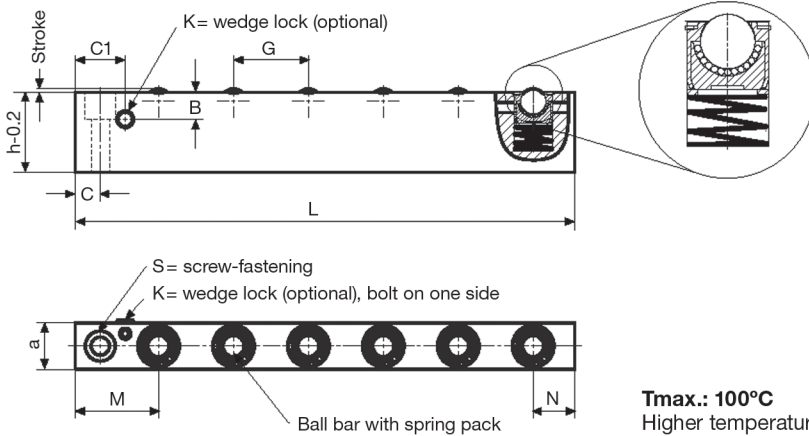

Tmax.: 100°C
Higher temperatures on request

Ball bar variations with spring pack

If the appropriate ball bar for your specific application is not included in the tables of standard bars, our range of variations offers a solution.

Fewer balls also means that the ball bar will be offered at a lower price. Select the slot height, the ball spacing and the bar length to create a variation for your application.

e.g. **a = 36 mm**
e.g. **fastening screw = S**

Within the limits stated in the table of dimensions, the following parameters can be freely selected:

Slot height (h)

If for your application the slots are not as high as in our standard design, indicate the corresponding dimension.

If for your application the slots are higher than our standard design, spacer bars may be inserted.

e.g. **h = 50 mm**

Spacing of balls (G) and load-bearing capacity of the ball bar

By changing the spacing of the balls the load-bearing capacity of the ball bar may be varied. Please note that the load-bearing capacity is indicated for the full length of the ball bar. Therefore, both the load-bearing capacity and the ball spacing must be selected to suit the die weight and the die supporting length.

Please indicate the desired ball spacing or load-bearing capacity of the ball bar, or the maximum die weight and the die dimensions.

e.g. **G = 35 mm**

or **load-bearing capacity per bar = 38 kN**

or **number of balls = 38**

or **die weight and outside dimensions**

Length of the ball bar (L)

The possible length of the bar is obtained from the ball spacing (G) and the parameter (M).

Just indicate the theoretical length (e.g. the length of the table) for your ball bar.

Please note that a ball bar must be equipped with at least 3 balls.

*) e.g. **L = 1380 mm**

Slot with (a)	(mm)	18	22	28	36	13/16"	11/16"
Slot height min. (h)	(mm)	29,4	38	48	46	29,4	38
Standard slot height (h)	(mm)	30	38	48	61	29,4	38,9
Ball spacing G min.	(mm)	20	23	28	34	20	23
Ball spacing G standard	(mm)	30	40	45	50	30	40
Ball spacing G max.	(mm)	60	80	90	100	60	80
L min.	(mm)	*)	*)	*)	*)	*)	*)
L max.	(mm)	2900	2900	2900	2900	2900	2900
Hub	(mm)	1	2	2	2	1	2
Load-bearing capacity ball	(kN)	0,22	0,42	1,63	1,00	0,22	0,42
B	(mm)	12	16	16	16	12	16
C	(mm)	10	12,5	15	20	10	12,5
C1	(mm)	10	24,5	30	35	10	24,5
D	(mm)	15	15	20	20	15	15
E	(mm)	M6	M8	M10	M10	M6	M8
M	(mm)	27,5	40	50	57,5	27,5	40
N	(mm)	12,5	15	25	27,5	12,5	15

*) L min. depends on the roller spacing G between at least 3 balls. Indication of the load per ball bar.

Annex K = Wedge lock

S = Screw fastening

Ordering example

8.9218. 7236 L1385 K without suffix
 Ball bar, Slot Length Standard Standard
 spring-loaded 36 mm 1385 mm slot ball
 height spacing
 Fastening of
 wedge lock

Ordering example

8.9218. 7236 L1380 S H50 G35
 Ball bar, Slot Length Slot Ball
 spring-loaded 36 mm 1380 mm height spacing
 50 mm
 Fastening of
 screw

Based on these parameters, we will devise the ball bar for your specific application.

Please contact us, we will be pleased to offer you advice!

Selection of ball bars in preferred sizes: slot height "h" and ball spacing "G"

For other slot heights, lengths and load-bearing capacities (or ball spacing), see range of variations page 1.

Part no.	Slot (a) (mm)	Length (L) (mm)	Max. load (kN)	Number of balls
8.9218.7218 L 100 S	18	100	0,6	3
8.9218.7218 L 130 S	18	130	0,8	4
8.9218.7218 L 160 S	18	160	1,1	5
8.9218.7218 L 190 S	18	190	1,3	6
8.9218.7218 L 250 S	18	250	1,7	8
* 8.9218.7218 L 310 S	18	310	2,2	10
8.9218.7218 L 370 S	18	370	2,6	12
8.9218.7218 L 430 S	18	430	3	14
* 8.9218.7218 L 490 S	18	490	3,5	16
8.9218.7218 L 550 S	18	550	3,9	18
8.9218.7218 L 610 S	18	610	4,4	20
8.9218.7218 L 670 S	18	670	4,8	22
8.9218.7218 L 730 S	18	730	5,2	24
Other intermediate lengths up to max. 2890 are possible.				
8.9218.7218 L 2890 S	18	2890	21,1	96
8.9218.7222 L 135 S	22	135	1,2	3
8.9218.7222 L 175 S	22	175	1,6	4
8.9218.7222 L 215 S	22	215	2,1	5
8.9218.7222 L 255 S	22	255	2,5	6
8.9218.7222 L 335 S	22	335	3,3	8
8.9218.7222 L 415 S	22	415	4,2	10
* 8.9218.7222 L 495 S	22	495	5	12
8.9218.7222 L 575 S	22	575	5,8	14
8.9218.7222 L 655 S	22	655	6,7	16
8.9218.7222 L 735 S	22	735	7,5	18
8.9218.7222 L 815 S	22	815	8,4	20
* 8.9218.7222 L 895 S	22	895	9,2	22
8.9218.7222 L 975 S	22	975	10	24
8.9218.7222 L 1055 S	22	1055	10,9	26
8.9218.7222 L 1135 S	22	1135	11,7	28
8.9218.7222 L 1215 S	22	1215	12,6	30
8.9218.7222 L 1295 S	22	1295	13,4	32
Other intermediate lengths up to max. 2895 are possible.				
8.9218.7222 L 2895 S	22	2895	30,2	72
8.9218.7228 L 165 S	28	165	1,8	3
8.9218.7228 L 210 S	28	210	2,5	4
8.9218.7228 L 255 S	28	255	3,1	5
8.9218.7228 L 300 S	28	300	3,7	6
8.9218.7228 L 390 S	28	390	5	8
8.9218.7228 L 480 S	28	480	6,3	10
8.9218.7228 L 570 S	28	570	7,5	12
8.9218.7228 L 660 S	28	660	8,8	14
8.9218.7228 L 750 S	28	750	10	16
8.9218.7228 L 840 S	28	840	11,3	18
8.9218.7228 L 930 S	28	930	12,6	20
8.9218.7228 L 1020 S	28	1020	13,8	22
Other intermediate lengths up to max. 2865 are possible.				
8.9218.7228 L 2865 S	28	2865	39,6	63

* Available at short notice

Part no.	Slot (a) (mm)	Length (L) (mm)	Max. load (kN)	Number of balls
8.9218.7136 L 185 S	36	185	3	3
8.9218.7136 L 235 S	36	235	4	4
8.9218.7136 L 285 S	36	285	5	5
8.9218.7136 L 335 S	36	335	6	6
8.9218.7136 L 435 S	36	435	8	8
8.9218.7136 L 535 S	36	535	10	10
8.9218.7136 L 635 S	36	635	12	12
8.9218.7136 L 735 S	36	735	14	14
8.9218.7136 L 835 S	36	835	16	16
8.9218.7136 L 935 S	36	935	18	18
8.9218.7136 L 1035 S	36	1035	20	20
8.9218.7136 L 1135 S	36	1135	22	22
Other intermediate lengths up to max. 2885 are possible.				
8.9218.7136 L 2985 S	36	2885	57	57
8.9218.7213 L 100 S	13/16"	100	0,6	3
8.9218.7213 L 130 S	13/16"	130	0,8	4
8.9218.7213 L 160 S	13/16"	160	1,1	5
8.9218.7213 L 190 S	13/16"	190	1,3	6
8.9218.7213 L 250 S	13/16"	250	1,7	8
8.9218.7213 L 310 S	13/16"	310	2,2	10
8.9218.7213 L 370 S	13/16"	370	2,6	12
8.9218.7213 L 430 S	13/16"	430	3	14
8.9218.7213 L 490 S	13/16"	490	3,5	16
8.9218.7213 L 550 S	13/16"	550	3,9	18
8.9218.7213 L 610 S	13/16"	610	4,4	20
8.9218.7213 L 670 S	13/16"	670	4,8	22
8.9218.7213 L 730 S	13/16"	730	5,2	24
Other intermediate lengths up to max. 2890 are possible.				
8.9218.7213 L 2890 S	13/16"	2890	21,1	96
8.9218.7217 L 135 S	11/16"	135	1,2	3
8.9218.7217 L 175 S	11/16"	175	1,6	4
8.9218.7217 L 215 S	11/16"	215	2,1	5
8.9218.7217 L 255 S	11/16"	255	2,5	6
8.9218.7217 L 335 S	11/16"	335	3,3	8
8.9218.7217 L 415 S	11/16"	415	4,2	10
8.9218.7217 L 495 S	11/16"	495	5	12
8.9218.7217 L 575 S	11/16"	575	5,8	14
8.9218.7217 L 655 S	11/16"	655	6,7	16
8.9218.7217 L 735 S	11/16"	735	7,5	18
8.9218.7217 L 815 S	11/16"	815	8,4	20
8.9218.7217 L 895 S	11/16"	895	9,2	22
8.9218.7217 L 975 S	11/16"	975	10	24
8.9218.7217 L 1055 S	11/16"	1055	10,9	26
8.9218.7217 L 1135 S	11/16"	1135	11,7	28
8.9218.7217 L 1215 S	11/16"	1215	12,6	30
8.9218.7217 L 1295 S	11/16"	1295	13,4	32
Other intermediate lengths up to max. 2895 are possible.				
8.9218.7217 L 2895 S	11/16"	2895	30,2	72

▼
S = screw

K = wedge lock

K