

Rotating Module DMHe 200 / DMVe 600

Electrically operated

Max. load 2,000 N, max. torque 120 Nm

M1.201

Issue 1-16 E



Advantages

- Versions for horizontal or vertical axis of rotation
- Rotating in both directions
- Auto stop
- Low-backlash gear
- Self-locking in any position
- Compact design
- Sturdy design
- Convertible
- Ergonomic working
- Safe and quick handling in assembly processes
- Long service life
- Checked in compliance with DIN EN 1570 with quadruple static overload

Principal use

- Assembly of automotive parts
- Motor assembly
- Gear assembly
- Pump construction

Operation

The module is operated with touch control by means of an optionally available hand panel or foot switch with two push-buttons. It can safely stop in every angular position. An automatic stop is preset at all 90° positions. The zero position of the automatic stop can be preset to any position by pushing both push-buttons.

Description

Rotating modules are used in assembly and handling processes to transform electrical energy into a rotating movement.

When using the rotating module, component parts can be rotated rationally, quickly and safely and can be assembled ergonomically from all sides.

The strongly reduced worm gear allows high holding torques in standstill.

The double-bearing drive shaft compensates high axial and radial forces.

The rotating module is designed for a long service life. The electronically commutated DC motor is virtually wear-free.

The mechanical components and sealing elements are designed for 1,000,000 indexing cycles within the indicated load limits.

The rotating modules – horizontal axis and vertical axis are nearly identical in construction, thus the axis alignment can be retrofitted for different applications.

modulog rotating modules electrically operated

- horizontal axis

DMHe 200

Part no. 6508-02-36-E

Max. load: 2,000 N

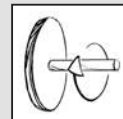

- vertical

DMVe 600

Part no. 6509-10-36-E

Max. load: 6,000 N



Technical data

Angle of rotation:	360°
Max. torque:	120 Nm
Max. holding torque:	350 Nm
Max. torque:	800 Nm
Rotation:	any
index:	90° standard optionally 45°/60°/180°

Operations

- Foot switch
- Hand panel



Combinable with the modules

Lifting modules

- Shop Floor Telescope: as per data sheet M 4.202
- Range: as per data sheet M 4.203
- Shop-Floor: as per data sheet M 4.301
- Strong: as per data sheet M 4.401
- Solid: as per data sheet M 4.402

modulog interfaces

- Flange plate: 140 x 140 - M10
- Body: 140 x 140 - M10

Accessories

- Switching power supply Part no. 6863-020
- Hand panel as per data sheet M 8.203
- Foot switch as per data sheet M 8.203



ROEMHELD
HILMA ■ STARK

Subject to change.

CARR LANE ROEMHELD MFG. CO.

Sales — Phone (636) 386-8022 Fax (636) 386-8034
Engineering — Phone 1-800-827-2526 Web www.carrlaneroemheld.com

Rotating module horizontal axis DMHe 200

Dimensions

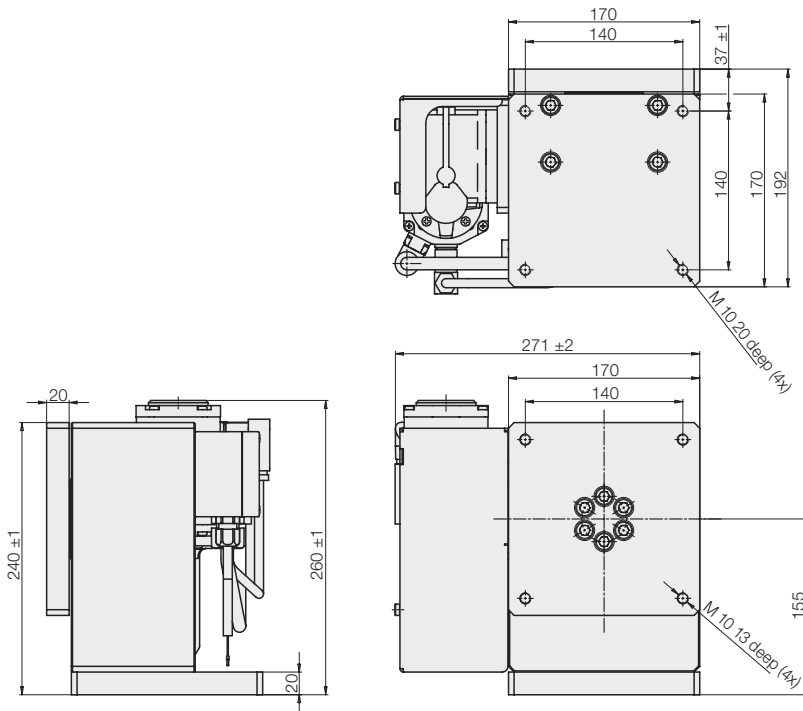

Part no. 6508-02-36-E

Installation

The rotating module has a *modulog* interface 140x140 mm and can be mounted by 4 screws M10 onto a fixture or another module. The power supply is made by the separately available switching power supply. An electronic control is integrated.

Technical data

Max. total F_x/F_y	[N]	2,000
Max. F_z	[N]	1,000
Max. driving torque M_z	[Nm]	120
Max. holding torque M_z	[Nm]	350
Max. total of all torques $M_x/M_y/M_z$	[Nm]	800
Max. cycle time (ED)		25 %, 60 s On
Code class		IP 54
Current consumption	[A]	6 ... 16
Max. admissible current consumption	[A]	20
Supply voltage	[V DC]	24–30

Adjust the speed of rotation by trimming potentiometer 2.5 to 7.5 rpm.
Adjust the indexing angles 45, 60, 90 and 180 degree by trimming potentiometer.
Adjust the soft stops by trimming potentiometer.

Maximum admissible load

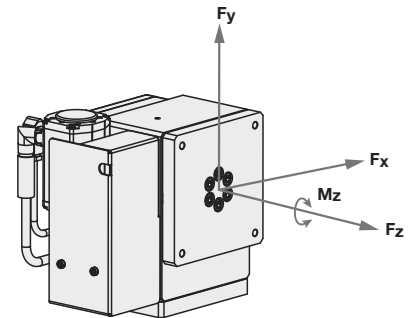

Maximum admissible forces:

$F_x = \pm 2,000$ N
 $F_y = \pm 2,000$ N
 $F_z = \pm 1,000$ N

Maximum admissible torques:

M_x or $M_y = 800$ Nm
 $M_z = 350$ Nm (in standstill)

The total of all occurring forces or torques must not exceed the highest single value.

The rotating module is checked in compliance with DIN EN 1570 with quadruple static overload.



ROEMHELD
HILMA ■ STARK

Subject to change.

CARR LANE ROEMHELD MFG. CO.

Sales — Phone (636) 386-8022 Fax (636) 386-8034

Engineering — Phone 1-800-827-2526 Web www.carrlaneroemheld.com

Rotating module vertical axis DMVe 200

Dimensions

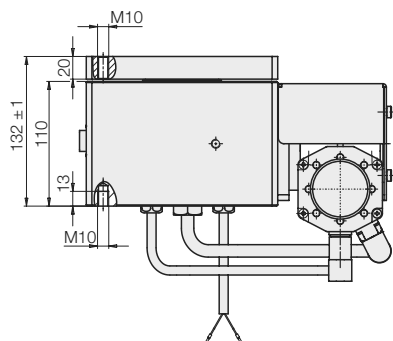

Part no. 6509-10-36-E

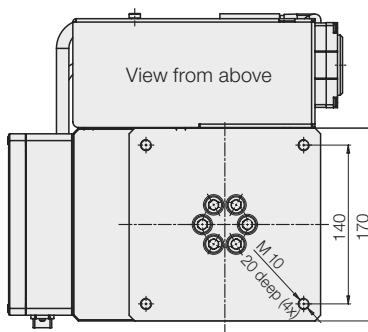
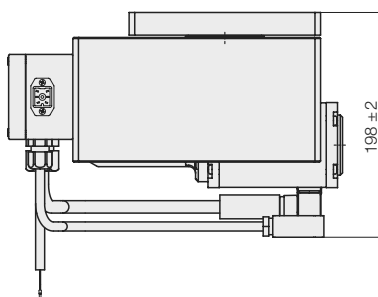
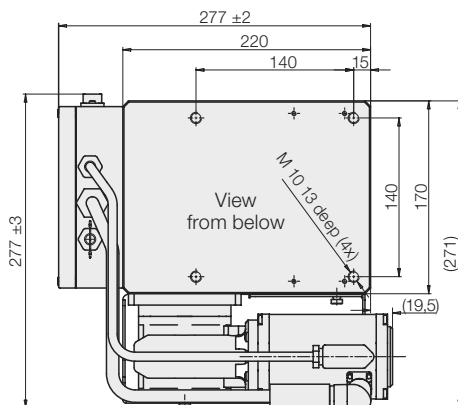

Technical data

Max. total F_x/F_y	[N]	2,000
Max. F_z	[N]	6,000
Max. driving torque M_z	[Nm]	120
Max. holding torque M_z	[Nm]	350
Max. total of all torques $M_x/M_y/M_z$	[Nm]	800
Max. cycle time (ED)	25 %, 60s On	
Code class	IP 54	
Current consumption	[A]	6...16
Max. admissible current consumption	[A]	20
Supply voltage	[V DC]	24-30

Adjust the speed of rotation by trimming potentiometer 2.5 to 7.5 rpm.

Adjust the indexing angles 45, 60, 90 and 180 degree by trimming potentiometer.

Adjust the soft stops by trimming potentiometer.

Maximum admissible load

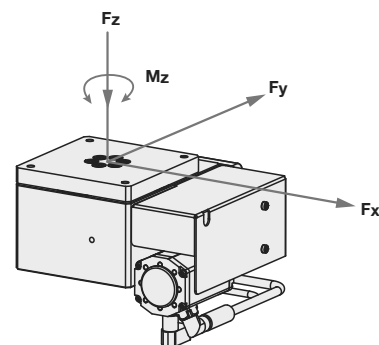

Maximum admissible forces:

$F_x = \pm 2,000$ N

$F_y = \pm 2,000$ N

$F_z = + 6,000$ N

Maximum admissible torques

M_x or $M_y = 800$ Nm

$M_z = 350$ Nm (in standstill)

The total of all occurring forces or torques must not exceed the highest single value.

The rotating module is checked in compliance with DIN EN 1570 with quadruple static overload.

Installation

The rotating module has a *modulog* interface 140x140 mm and can be mounted by 4 screws M10 onto a fixture or another module. The power supply is made by the separately available switching power supply.

An electronic control is integrated.

When mounting onto a flat surface an elevation of the module has to be provided because of protruding components.



ROEMHELD
HILMA ■ STARK

Subject to change.

CARR LANE ROEMHELD MFG. CO.

Sales — Phone (636) 386-8022 Fax (636) 386-8034

Engineering — Phone 1-800-827-2526 Web www.carrlaneroemheld.com